

CRAWLER BULLDOZER ZD160(S)-3/6



ZOOMLION



CRAWLER BULLDOZER

ZD160(S)-3/6

	Items	ZD160-3/6	ZD160S-3/6
Engine	Manufacturer	WEICHAI	WEICHAI
	Model	WD10G178E25 / WP10G178E355	WD10G178E25 / WP10G178E355
	Displacement	9.726 L	9.726 L
	Rated Speed	1850 r/min	1850 r/min
	Rated Power	131 kW	131 kW
	Electric Generator	28 V、1.54 kW	28 V、1.54 kW
	Fuel Consumption Rate	≤215/191 g/kW·h	≤215/191 g/kW·h
	Starter Motor	24 V、6.6 kW	24 V、6.6 kW
Undercarriage	Width of Track Shoe	510 mm	950 mm
	Pitch	203.2 mm	203.2 mm
	Track Gauge	1880 mm	2300 mm
	Length of Track On Ground	2430 mm	2935 mm
	Ground Clearance	400 mm	444 mm
	Number of Track Shoes (per side)	37 piece	42 piece
Working Device	Blade Type	Straight tilt blade	Swamp straight tilt blade
	Width	3451 mm	4150 mm
	Height	1143 mm	1039 mm
	Max. Lift of Blade Above Ground	1087 mm	1052 mm
	Max. Drop of Blade Below Ground	562 mm	450 mm
	Blade Capacity	4.5 m ³	4.7 m ³
Dimensions and Weight	Operating Weight	16500 kg	18100 kg
	Length (without ripper)	5050 mm	5305 mm
	Length (with multi-shank ripper)	6360 mm	/
	Width	3451 mm	4150 mm
	Height (to top of cab)	3068 mm	3140 mm

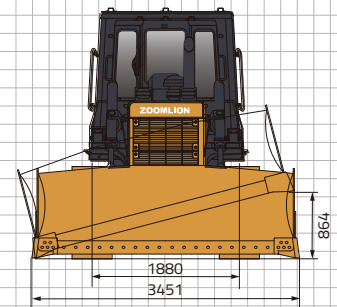
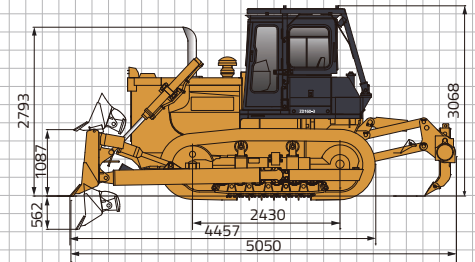

*This document is non-contractual. Constant improvement and engineering progress make it necessary that we reserve the right to make specification, equipment and price changes without notice. Illustrations shown are subject to modification and may include optional equipment and accessories, or may not include all standard equipment.

ZOOMLION

Zoomlion Heavy Industry Science & Technology Co.,Ltd.

Add: No.361, South Yinpen Road, Changsha, HunanProvince, P.R.China 410013
Copyright©2024 Zoomlion. All rights reserved. Reproduction and copying of any part of contents is not allowed for any purposes without Zoomlion's approval.

Email: earthmoving@zoomlion.com

Note: Materials and specifications are subject to change without notice. Featured machines in photos may include additional equipment.

