

# ZOOMLION TECHNOLOGY WITH INGENUITY AND CARE



## THE WORLD'S LEADING EXCAVATOR INTELLIGENT MANUFACTURING FACTORY

ZOOMLION Smart City Earthmoving Machinery Park is an industry-leading intelligent and flexible excavator factory. From a piece of steel plate to an excavator, with high-precision welding process, highly reliable assembly process, high-level coating process and strict quality control, each excavator is delivered with ultimate quality.

**ZOOMLION**

**Zoomlion Heavy Industry Science & Technology Co.,Ltd.**

Add: Zoomlion Smart City Headquarters Building, No.613 Naqiu Road, Wangcheng District, Changsha, Hunan, China 410221  
Email: [earthmoving@zoomlion.com](mailto:earthmoving@zoomlion.com)

Copyright © Zoomlion. All rights reserved. Reproduction and copying of any part of contents is not allowed for any purposes without Zoomlion's approval.  
Note: Materials and specifications are subject to change without notice. Featured machines in photos may include additional equipment.



# ZOOMLION WHEEL LOADER

## ZWL75GE



**ZOOMLION**

# VISION CREATES FUTURE

## ZWL75GE

Operating Weight : 25300 kg

Rated Payload : 7500 kg

Bucket Capacity : 5.0 m<sup>3</sup>

Machine power : 215 kW

Battery Capacity : 423 kWh



# CONFIGURATION & EFFICIENCY

## BATTERY, MOTOR AND MCU WITH HIGH RELIABILITY



Battery system

The battery system is designed with ultra-long service life, superior charge-discharge efficiency and enhanced safety performance.

- Engineered for 4,000+ charge cycles ;
- Heavy-duty electrical box with IP68 protection rating;
- Dual-gun fast charging support, achieving a full charge in as little as 1.5 hour.



Underwater protection test



Large-capacity power battery pack

The motor system features super-long service life, substantial power output, and optimal efficiency

- Equipped with a high-speed permanent magnet synchronous motor, it achieves a maximum efficiency of 95% and a peak torque of 1,400 Nm, featuring quick response, robust power, and a design life of over 20,000 hours;
- With the design of a high-speed motor and a large gear ratio box, the motor's allowable peak speed reaches 9,400 rpm for an even faster dynamic response.

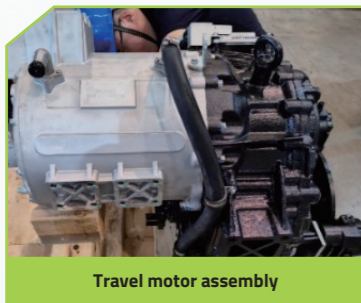

Travel motor assembly

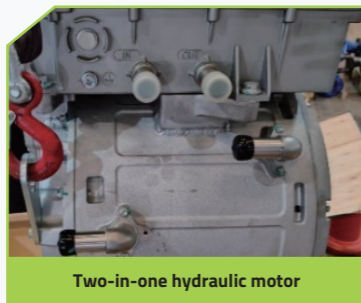

Two-in-one hydraulic motor

Smart and versatile electronic-control system

- Five-in-one integrated controller with optimal efficiency;
- Delivering comprehensive safeguards against over-voltage, overcurrent, and overheating.



Five-in-one controller



Integrated smart temperature control module

## CONVENIENT CHARGING



Highly-compatible charging interfaces

Dual-gun charging boosts charging power and shortens charging time.



Charging pile power	Charging time (423 kWh battery, 20-100%)
320KW Charging station	1.5h
240KW Charging station	1.8h

High adaptability to charging environments

- Featuring temperature detection and over-temperature protection for charging interfaces;
- The charging environment temperature range is -30 °C to 50 °C.

Speedy charging

- Ultra-high-speed charging: Charging time < 1.5 hour with a 320 kW charging pile.

## ENERGY-SAVING AND HIGHLY-EFFICIENT



**Smart frequency-modulating energy management system:** Dynamically adjusting the RPM of motors and water pumps based on ambient temperature and operating conditions; Reducing energy consumption of auxiliary components while enhancing power utilization efficiency.



**Smart temperature control system:** Featuring high power cooling and heating power system that automatically responds to the heat-ing or cooling demands of batteries, motors MCU, and the cab.

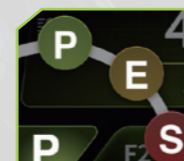

**Multi-power mode of P/S/E:** Seamlessly switching between powerful, standard, or economic modes to meet your needs  
**Idle speed management function:** The motor RPM can be adjusted within an idle range of 600-900 rpm;  
**Energy recovery:** The maximum energy recovery rate during sliding braking is over 60%.



**Integrated machine thermal management module:** Realizing battery heating or cooling, cab heating or cooling as well as heat dissipation for electric drive and electronic control system, which significantly reduces invalid heat loss.

# PERFORMANCE ADAPTABILITY



**Full-hydraulic braking system**

It features precise control, rapid response, and strong braking force, and can adapt to harsh environments such as high and low temperatures and high dust levels.

Independent braking of front and rear drive axles improves driving safety.



**Optional wet-type drive axle**

Exceptional braking performance with efficient heat dissipation; Sealed design prevents muddy water from entering the brake chamber, maintaining excellent braking performance even in wading or muddy conditions.



**Optional 360° surround view camera**

It eliminates blind spots to significantly enhance safety, and features easy operation to reduce driver fatigue.



**Good adaptability to high and low temperatures**

Integrated smart temperature control system, BMS battery thermal management real-time monitoring (heating: water heating, cooling: water cooling), meeting the working environment temperature of -30 °C to 50 °C.

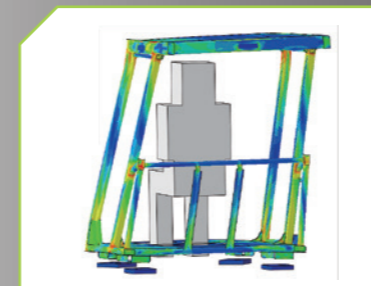

**FOPS & ROPS cab**

Adopting an enclosed structure welded with high-strength steel, Satisfy the weight of the entire machine ranging from 25 tons to 27 tons. Meeting the international standard certification of ISO3449/3471, it is specially designed for medium and large loaders with ultimate safety protection.

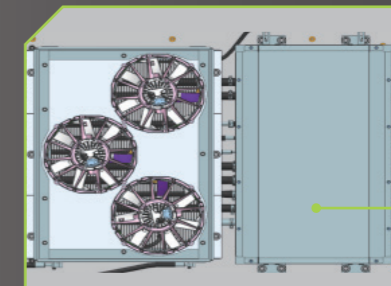

Integrated water-cooled unit

**Strong adaptability to high dust and high humidity environments**

The internal and external gaps of inlet and outlet wiring harnesses are all sealed, Motor electrical components have an IP67 protection rating, while the battery has an IP68 protection rating, providing dust and water resistance.

# RELIABILITY & DURABILITY

## ● High-strength wing-box front frame

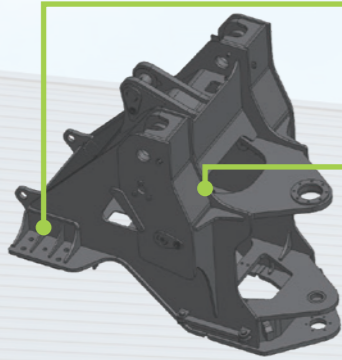

Reinforced front axle mounting seat, with additional "U-shaped support ribs" structure, can effectively distribute heavy front axle loads and enhance reliability.

Reinforced left and right wing-box structures with a 6% increase in cross-sectional area, enhancing load-bearing capacity.

## ● High-load-bearing articulated rear frame

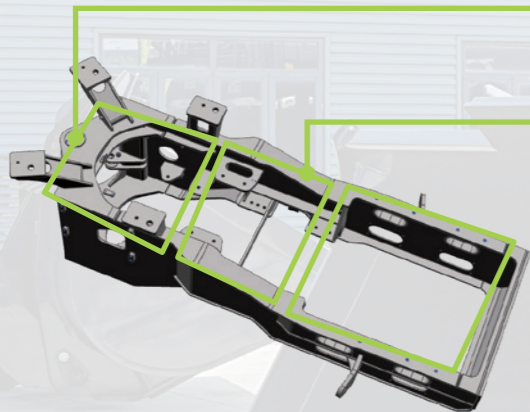

Large-sized articulated opening effectively bears heavy transverse torque loads on the frame.

Large-sized web height effectively bears the longitudinal vertical loads of the frame. This structure has obtained a utility model patent: A Reinforced Rear Frame for Three-Section Loaders.

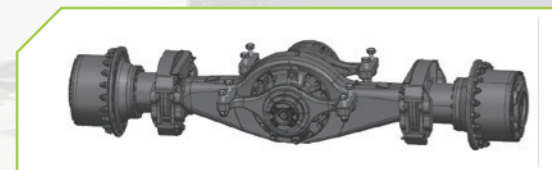

### Heavy-duty drive axle

High static load capacity ensures reliability under extreme working conditions; The rear axle adopts an integrated cast swing frame, featuring strong load-bearing capacity and low failure rate; Fully hydraulic caliper braking, safe and reliable.

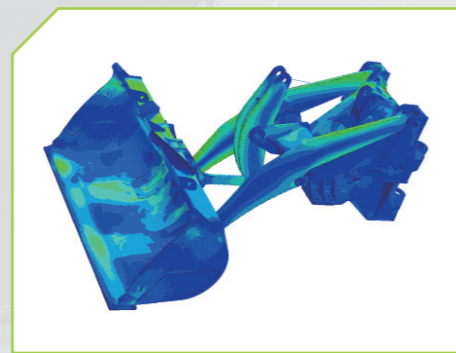

### High reliability verified by sufficient testing

Structural parts undergo CAE analysis to reduce stress concentration; Dynamic loading test stands and extreme fatigue durability tests are fully utilized to ensure the high reliability of the structure.

## SAFE AND RELIABLE INTERMEDIATE HINGE

The intermediate articulation is equipped with double tapered roller bearings, featuring strong load-bearing capacity and adaptability to high-intensity harsh working conditions.



Double tapered roller bearings



Upper articulation assembly



Lower articulation assembly



Equipped with multiple original patented technologies and subjected to thousands of quenching cycles under harsh working conditions, the control commands are precise to the millisecond level, resulting in a 50% increase in product reliability and durability.

The patent support is as follows:

1. Control and Method of Adaptive Power Matching System for Electric Loader;
2. Design of Energy Recovery System for Electric Loader Based on AI.

# COMFORT & INTELLIGENCE



## SEDAN-LEVEL EXPERIENCE BRINGS MAXIMUM DRIVING COMFORT



Integrated large-sized main touch screen with rearview function



Push start



Fan and sunshade



1. 12.3-inch LCD dashboard  
2. Equipped with fault detection and fault codes display.

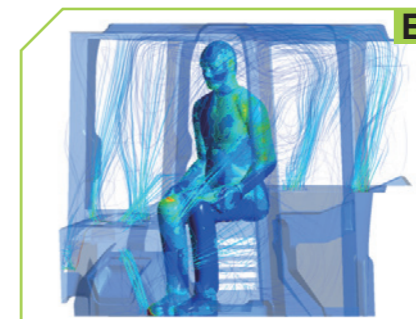

The cab is hermetically sealed with a pressure of +50 Pa, and equipped with N95-class filter elements, with a PM2.5 filtration efficiency of  $\geq 99\%$

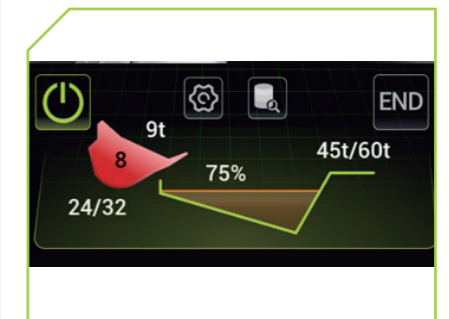

Equipped with standard features such as automatic leveling, automatic lifting, floating lowering, and optional automatic weighing, the operation is more convenient.



With 360° large-area panoramic glass stretching to the floor, the vision area reaches 3.52 m<sup>2</sup>, the largest in the industry, ensuring extremely broad operational visibility.



Spacious operating space, adjustable armrest box and handle, providing a more comfortable driving experience.

# CONVENIENT MAINTENANCE



The engine hood can tilt backward by more than 60°, providing convenient maintenance, repair and inspection for internal filters with a large service space.



The pilot filter and brake filter are centrally arranged on the right side, within easy reach for maintenance and convenience.



Grease lubrication points are centrally led out for ground-level access, enabling convenient daily maintenance.

# CUSTOMER SERVICE

Zoomlion's service technicians are distributed in key countries worldwide. Based on customers' equipment distribution, technicians maintain long-term stationed presence, ensuring immediate response to customer needs. Every year, Zoomlion service technicians carry out the Service Tour to visit both new and old customers to collect rational suggestions and attentively listen to service demands.

We promptly fulfill customers' needs and respond to reasonable requests.

We provide training for operators of each equipment, fully committed to ensuring stable operation of customer equipment.



# TECHNICAL PARAMETERS

Category	Item	ZWL75GE
Overall Machine Parameters	A Hinge pin height at maximum lift	4840 mm
	B Max. dump height (45° dump angle)	3540 mm
	C Dump reach (Max. dump height)	1215 mm
	D Digging depth	100 mm
	E Max. working height	6535 mm
	M Steering angle	40°
	Angle of departure	27°
	Bucket back-tilt angle on ground	45°
	Bucket back-tilt angle in transport	48°
	Bucket back-tilt angle in maximum dump height	61°
	Bucket dump angle in highest position	45°
	R1 Turning radius (outside bucket)	7540 mm
	R2 Turning radius (outside tire)	6570 mm
	L Overall length	9510 mm
	W Overall width	3400 mm
	G Wheelbase	3650 mm
	J Tread	2380 mm
	E Ground clearance	480 mm
	K Width over tires	3110 mm
Counterweight width	2260 mm	
H Overall height	3660 mm	

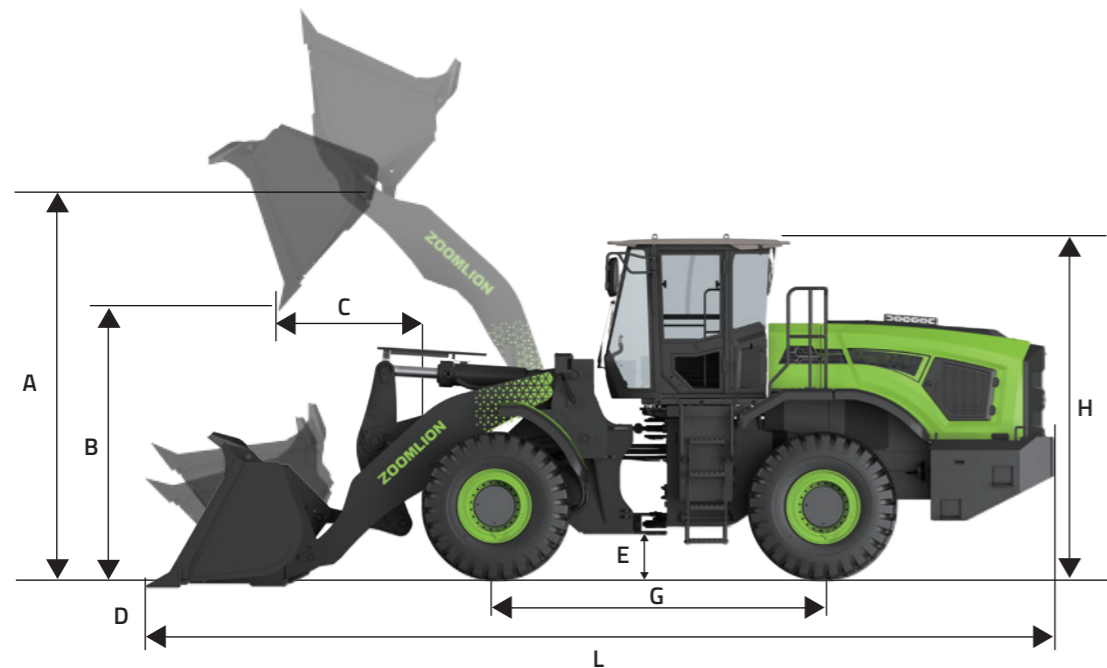

Category	Item	ZWL75GE
Configuration	Operating weight	25300 kg
	Bucket capacity	5(4.0-7.0) m <sup>3</sup>
	Rated payload	7500 kg
	Boom length (long reach)	3395 mm
Performance	Forward speed	15/39 km/h
	Reverse speed	15 km/h
	Lift-dump-descend time	10 s
	Max. rimpull	230 kN
	Bucket breakout force	215 kN
	Tipping load, straight	190 kN
	Tipping load, full turn	165 kN
Battery, motor, and MCU	Travel motor peak power	320 kW
	Hydraulic motor peak power	180 kW
	Nominal voltage	618 V
	Max. charging power	280 kW
	Battery capacity	423 kWh
Hydraulic system	System type	Fixed-variable displacement hydraulics
	Steering pump type	Swash-plate variable piston pump
	Working pump type	Silent gear pump
	Braking pump type	Gear pump
	Steering system pressure	21 Mpa
	Working system pressure	25 Mpa
	Braking system pressure	13 Mpa
Traveling parameters	Tire model	26.5-25 32PR
	Transmission type	AMT
	Max. travel speed	39 km/h
	Min. turning radius	6240 mm
	Min. ground clearance	480 mm
	Max. gradeability	27° Slope

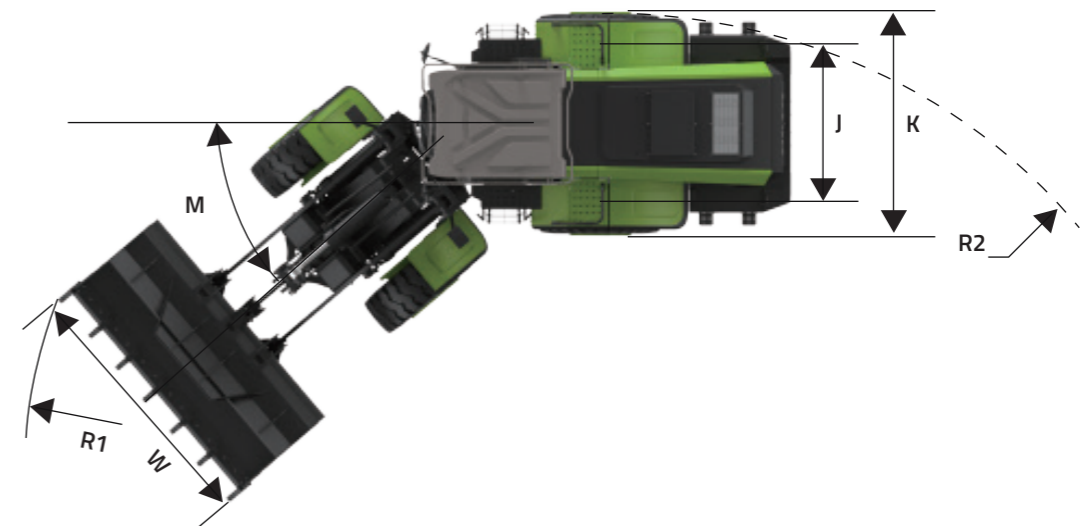

# STANDARD & OPTIONAL EQUIPMENT

Category	Configuration	ZWL75GE
Battery	423kWh Battery pack	●
	Dual-gun fast charging	●
Drivetrain	AMT transmission (two speed)	●
	High-speed single-motor drive	●
	Dry axle	●
	Wet axle	○
	Rear axle oscillation	●
Cooling system	26.5-25 32PR Diagonal tire	●
	Continuously variable speed control for radiator fan	●
	Fan counter-rotation	●
	Smart temperature-based fan control	●
	Smart temperature-based water-pump control	●
Hydraulic system	Low coolant level alarm	●
	Fixed-variable displacement hydraulics	●
	Single hydraulic motor	●
	Hydraulic service brake	●
	Dual circuit brake	●
	Hydraulic caliper disc parking brake	●
	Brake pressure detection and low-pressure alarm	●
	Electro-proportional single-handle pilot operation	●
	Electro-proportional fingertip control	○
	Automatic lubrication	○
Electrical system	Working mode selection (P/S/E)	●
	Electro-proportional joystick with FNR function	●
	Pilot safety switch function	●
	Back-up buzzer	●
	Back-up camera	●
	360° surround view system	○
	Cruise control	●
	Parking switch	●
	12.3-inch LCD instrument + 10-inch touch screen monitor	●
	LED rotating beacon	○
	GPS remote vehicle lock	●
	Automatic weighing system	○
	Back-up radar	○
	Overspeed alarm + Automatic auxiliary braking speed limiter	●
	Idle speed energy-saving management: 900 rpm working speed, 600 rpm	●
Operator's cab	Automatic lifting stop at top position and automatic leveling	●
	Mechanical suspension seat	●
	Air suspension seat	○
	Automatic air conditioner	●
	Radio and loudspeaker	●
	Storage box	●
	Cigarette lighter, lamp	●
	Seat belt	●
	Safety hammer	●
	File pocket, fire extinguisher	●
	Adjustable steering wheel	●
	Electronic throttle pedal	●
	Brake pedal with angle sensor	●
	Electric tip-up hood	●
	Bucket	5.0 m³ Gravel bucket
5.0 m³ Gravel bucket		○
5.5 m³ Flat bottom bucket		○
6.0 m³ Flat bottom bucket		○
7.0 m³ Flat bottom bucket		○
	4.0 m³ Rock bucket	○

● STANDARD ○ OPTIONAL



## ATTACHMENTS

### DIVERSIFIED AND SERIALIZED ATTACHMENTS

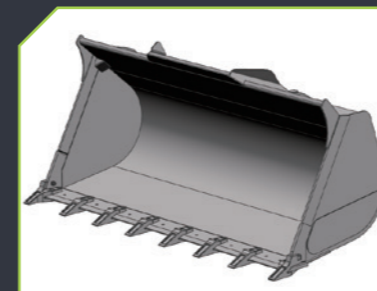

Gravel Bucket

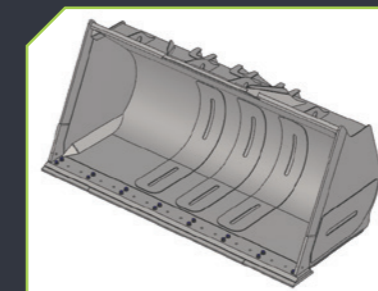

Flat Bottom Bucket

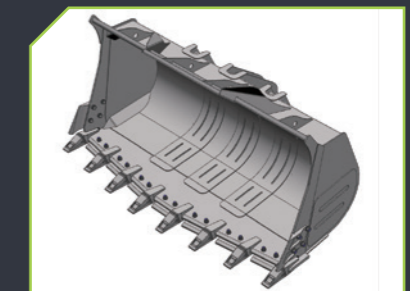

Rock Bucket

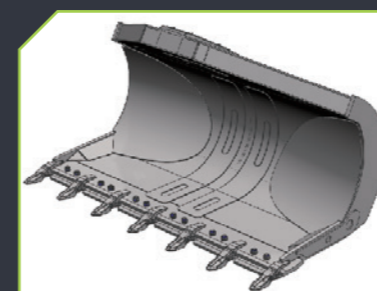

Side dump bucket

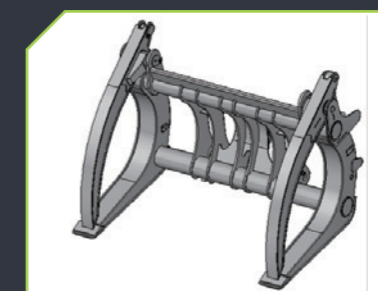

Wooden fork

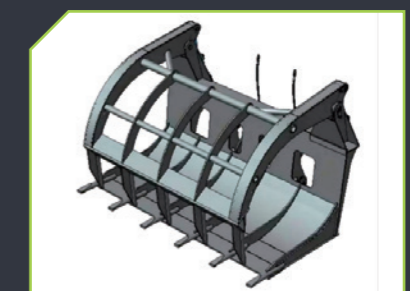

Grass fork